



## Chuangxin Online Test Center Laboratory

Add: F/r 401 Building A, Ying Da Feng industrial No,393,Jihua Rd.LongGang  
Dis. Shenzhen China  
Tel: 0755-83765367 Email: taow@iclab-cn.com



Report No:	SZ09132021017
Date:	2021/09/13
Page:	1/8

# Project Inspection Report

Company : NA  
Address : NA  
Sample Name : AH3761-WG-7  
Manufacture : DIODES  
Date Code : N/A  
Package Type : SOT23  
Sample Number : 10 PCS  
Check Number : 10 PCS  
Date of Received : 09/09/2021  
Date of Tested : 10:00/09/10/2021 ~ 12:00/09/10/2021

### WE HEREBY CERTIFY THAT:

The test(s) shown in the attachment were conducted according to the indicating procedures. We assume full responsibility for the accuracy and completeness of these tests and vouch for the qualifications of all personnel performing them.

Inspected by Engineer  
Wei-Tao

Reviewed by Project Manager  
Felix

### **Note:**

1. This report will be invalid if reproduced in whole or in part.
2. This report refers only to the specimen(s) submitted to test, and is invalid if used separately.
3. This report is only valid with the examination seal and signature of this institute.
4. The tested specimen(s) will only be preserved for thirty days from the date issued, if not collected by the applicant.
5. This report is only responsible for the samples tested.

## Items test



## Chuangxin Online Test Center Laboratory

Add: F/r 401 Building A, Ying Da Feng industrial No,393,Jihua Rd.LongGang  
Dis. Shenzhen China  
Tel: 0755-83765367 Email: taow@iclab-cn.com



Report No:	SZ09132021017
Date:	2021/09/13
Page:	2/8

- External visual inspection
- Pin Correlation Test
- Programming test
- Solder ability Analysis
- Radiography (X-ray)
- ROHS test
- Key Functional Testing (KFT)
- Baking
- Tape and Reel
- Internal visual inspection
- Top permanency test

## Methods & Equipment

### 1.1 Applicable Standard

- MIL-STD-883L-2019 2012.11

### 1.2 Optical Microscope

- Equipment Spec:  
Top view: FINIAL Hi-scope System SEZ-260: X7 ~ X45

### 1.3 Digital Caliper

- Equipment Spec:  
MASTERPROOF : Standard Digital Caliper 0-150mm

### 1.4 Radiography (X-ray)

- Equipment Spec:  
Hardware:XiDAT Dage XD6500  
Software:11.56-DD6058  
Magnification in excess of 2800x  
Resolution below 2um  
Energy:60KV/40uA

### 1.5 Testing Environment

- Ambient Temperature: 25±5°C
- Relative Humidity: 45%-65% RH

### 1.6 Testing Base



## Chuangxin Online Test Center Laboratory

Add: F/r 401 Building A, Ying Da Feng industrial No,393,Jihua Rd.LongGang  
Dis. Shenzhen China  
Tel: 0755-83765367 Email: taow@iclab-cn.com



Report No:	SZ09132021017
Date:	2021/09/13
Page:	3/8

[DIODES AH3761-WG-7]

[https://easydatasheet.cn/static/pdf\\_view/viewer.html?file=https://easydatasheet.cn/pdf/view/3a09d1f01c8ed19b8fa563e6bacfe45b5612c40f.pdf](https://easydatasheet.cn/static/pdf_view/viewer.html?file=https://easydatasheet.cn/pdf/view/3a09d1f01c8ed19b8fa563e6bacfe45b5612c40f.pdf)

## Analysis Summary

### X-ray Analysis:

Applicable Standard: MIL-STD-883L-2019 2012.11

X-ray inspection on 10PCS(#1-#10) samples. Two internal structures were found, #1、#3、#5、#7、#9、#10 Have the same internal structure, #2、#4、#6、#8 Have the same internal structure, But no abnormality was found such as bonding wire breaking and melting.

## 1. Device Description:

AH3761 is an integrated Hall effect latched sensor designed for electronic commutation of brush-less DC



Report No:	SZ09132021017
Date:	2021/09/13
Page:	4/8

motor applications. The device includes an on-chip Hall voltage generator for magnetic sensing, a comparator that amplifies the Hall voltage, and a schmitt trigger to provide switching hysteresis for noise rejection, and open drain output. An internal bandgap regulator is used to provide temperature compensated supply voltage for internal circuits and allows a wide operating supply range.

## 2. Package Dimensions:

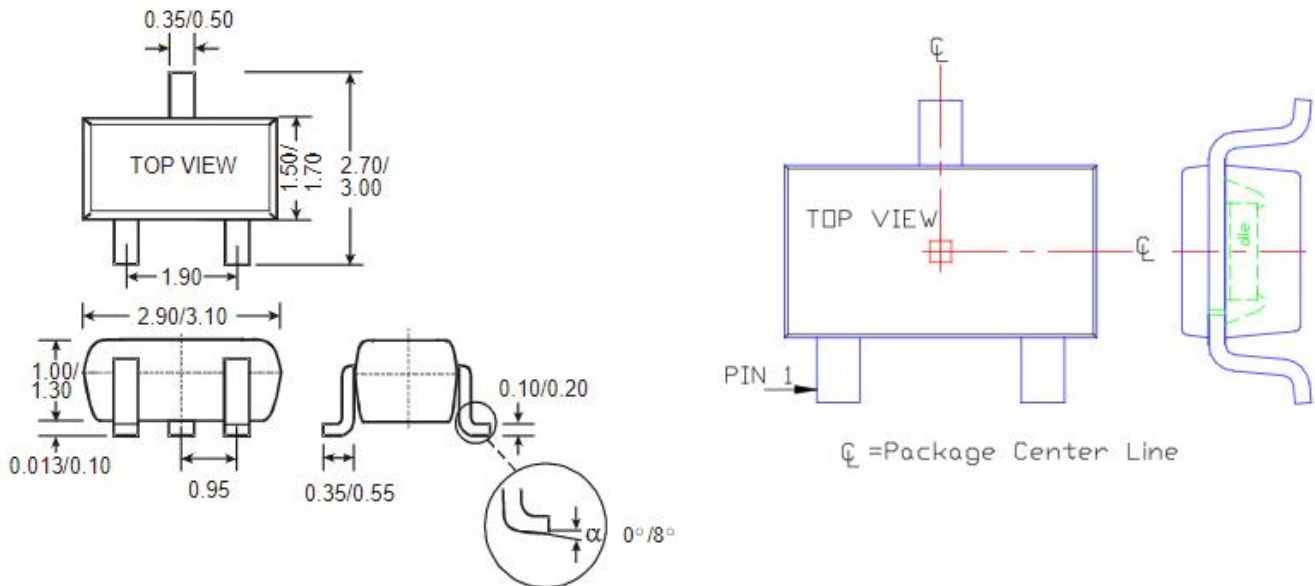

## 3.Receiving Inspection:



# Chuangxin Online Test Center Laboratory

Add: F/r 401Building A, Ying Da Feng industrial No,393,Jihua Rd.LongGang  
Dis. Shenzhen China  
Tel: 0755-83765367 Email: taow@iclab-cn.com



Report No:	SZ09132021017
Date:	2021/09/13
Page:	5/8

Gross Weight	25 g	Parts Total	10 PCS
Number Of Boxes	N/A	Full Label	Acceptable
Package type	Bulk	Moisture protection	Non Present
MSL	N/A	ESD protection	Acceptable

Received View-1



Received View-2



Received View-3

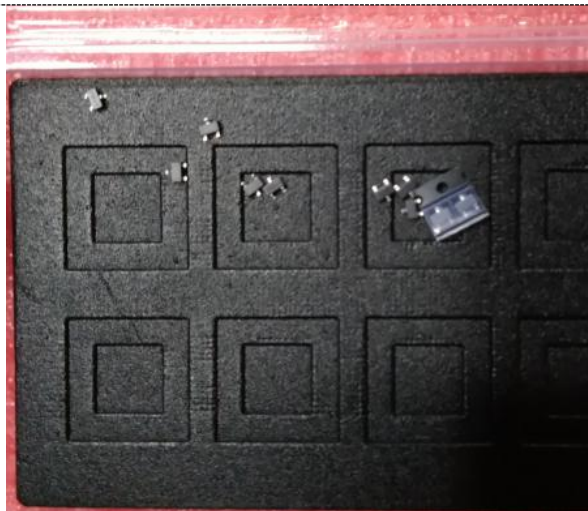



Report No:	SZ09132021017
Date:	2021/09/13
Page:	6/8

## 4.X-ray Analysis:

Applicable Standard: MIL-STD-883L-2019 2012.11

X-ray inspection on 10PCS(#1-#10) samples. Two internal structures were found, #1、#3、#5、#7、#9、#10 Have the same internal structure, #2、#4、#6、#8 Have the same internal structure, But no abnormality was found such as bonding wire breaking and melting.

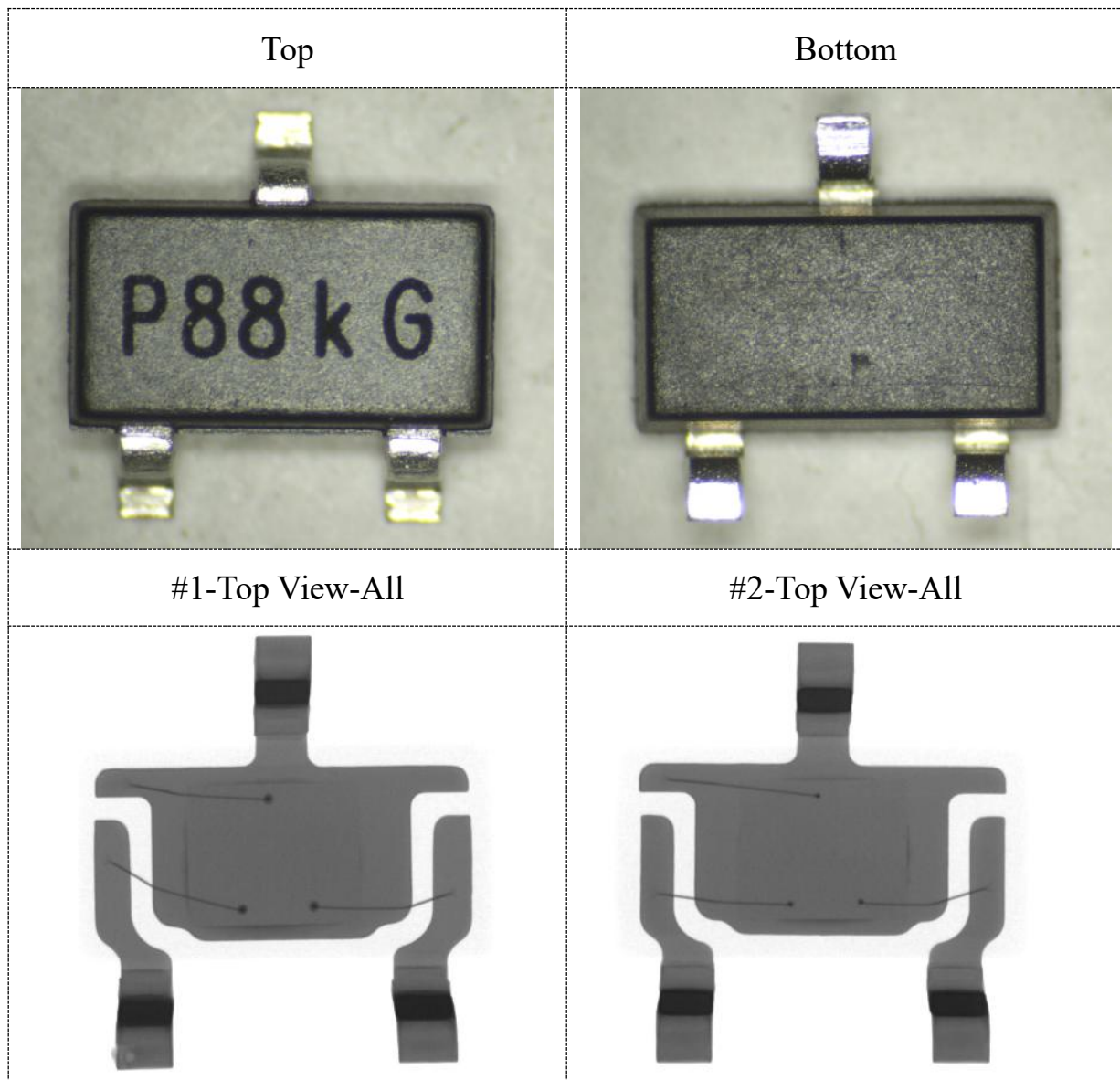





# Chuangxin Online Test Center Laboratory

Add: F/r 401 Building A, Ying Da Feng industrial No,393,Jihua Rd.LongGang  
Dis. Shenzhen China  
Tel: 0755-83765367      Email: taow@iclab-cn.com



Report No:	SZ09132021017
Date:	2021/09/13
Page:	7/8

#3-Top View-All

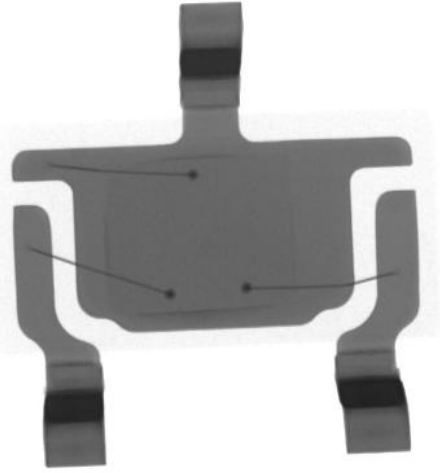

#4-Top View-All

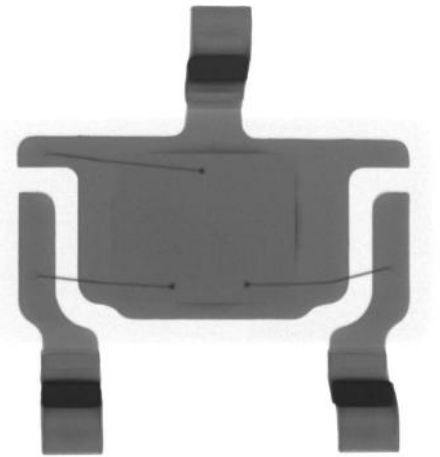

#5-Top View-All

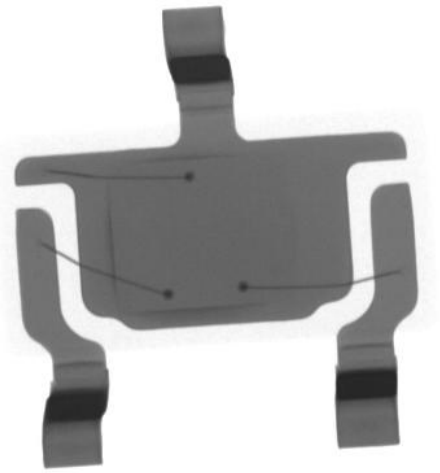

#6-Top View-All

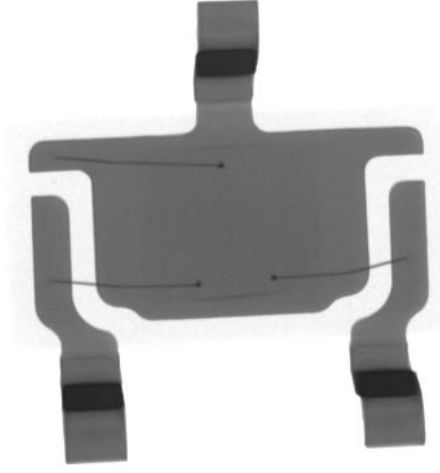

#7-Top View-All

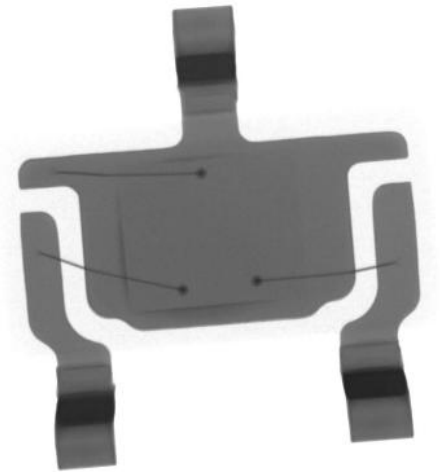

#8-Top View-All

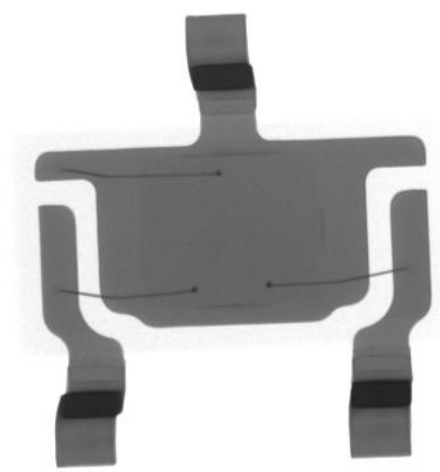



# Chuangxin Online Test Center Laboratory

Add: F/r 401Building A, Ying Da Feng industrial No,393,Jihua Rd.LongGang  
Dis. Shenzhen China  
Tel: 0755-83765367 Email: taow@iclab-cn.com



Report No:	SZ09132021017
Date:	2021/09/13
Page:	8/8

#9-Top View-All

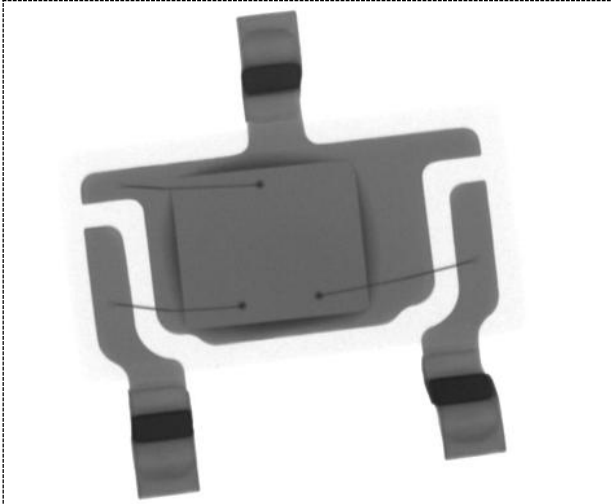

#10-Top View-All

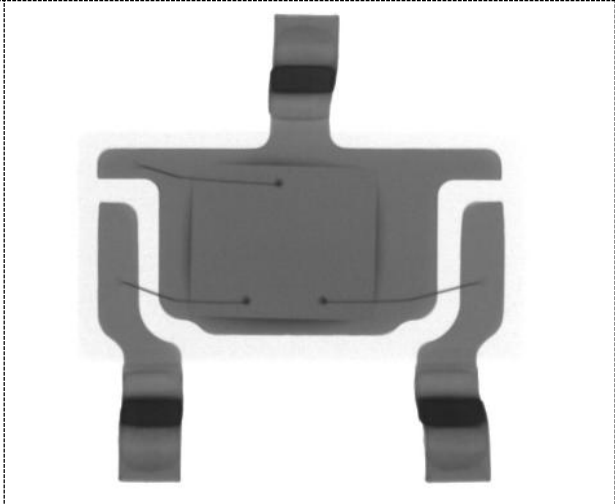

**End**

For more information, please visit: <http://www.iclabcn.com>

CXO Lab WeChat official account

